

ALLROUNDER 270 S COMPACT

Distance between tie bars: 270 x 270 mm

Clamping force: 350 kN

Injection unit (acc. to EUROMAP): 100

ARBURG

MACHINE DIMENSIONS | 270 S COMPACT

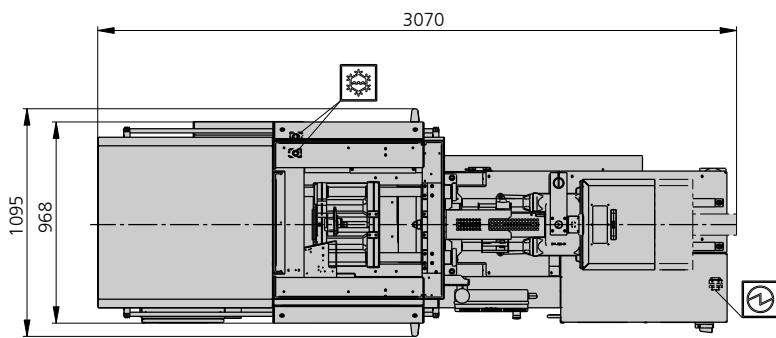
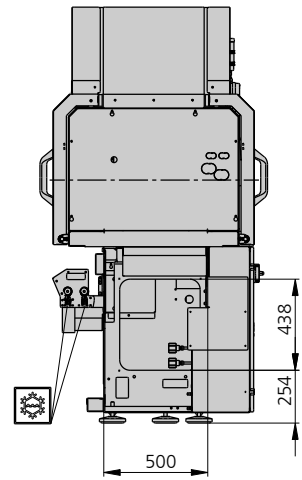
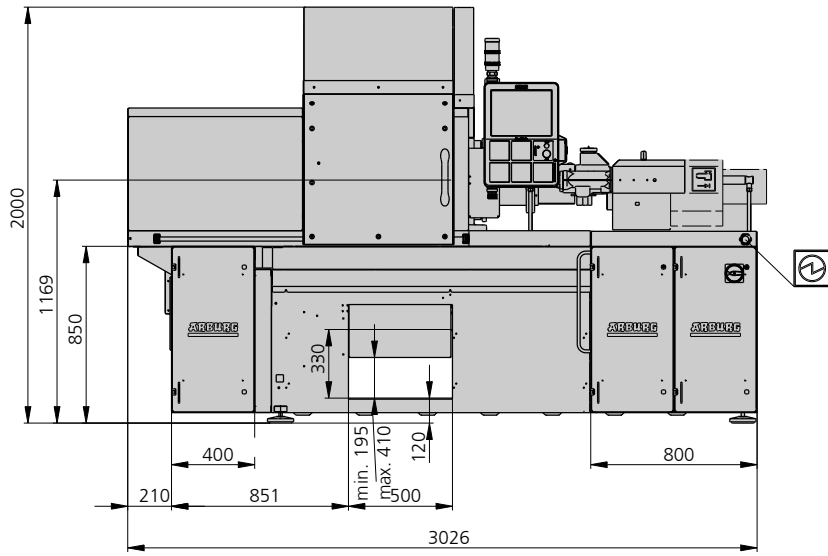

Electrical connection



Cooling water connection

TECHNICAL DATA | 270 S COMPACT

Clamping unit		270 S
with clamping force	max. kN	350
Opening force stroke	max. kN mm	90 350
Mould height, fixed variable	min. mm	200 ---
Platen daylight fixed variable	max. mm	550 ---
Distance between tie bars (w x h)	mm	270 x 270
Mould mounting platens (w x h)	max. mm	380 x 380
Weight of movable mould half	max. kg	135
Ejector force stroke	max. kN mm	20 100
Dry cycle time EUROMAP ²	min. s - mm	2,0 - 189

Injection unit		100		
with screw diameter	mm	20	25	30
Effective screw length	L/D	25	20	16,7
Screw stroke	max. mm	100		
Calculated stroke volume	max. cm ³	31	49	71
Shot weight	max. g PS	29	45	65
Material throughput	max. kg/h PS	5,5	8	9,5
	max. kg/h PA6.6	2,8	4	4,9
Injection pressure	max. bar	2500	2000	1390
Holding pressure	max. bar	2500	2000	1390
Injection flow ²	max. cm ³ /s	64	100	146
Screw circumferential speed ²	max. m/min	28	35	42
Screw torque	max. Nm	120	150	180
Nozzle contact force retraction stroke	max. kN mm	50 180		
Heating capacity zones	kW	4,9 5		
Feed hopper	l	50		

Drive and connection		100
with injection unit		100
Net weight of machine	kg	2000
Sound press. level Insecurity ⁴	dB(A)	68 3
Oil filling	l	130
Drive power ²	max. kW	11
Electrical connection ³	kW	18
	Total	A
	Machine	A
	Heating	A
Cooling water connection	max. °C	30
	min. Δp bar	1,5 DN 25

Machine type
with EUROMAP size designation ¹
270 S compact 350-100

All specifications relate to the basic machine version. Deviations are possible depending on variants, process settings and material type. Depending on the drive, certain combinations, e.g. max. injection pressure and max. injection flow may be mutually exclusive.

- 1) Clamping force (kN) - size of injection unit = max. stroke volume (cm³) x max. injection pressure (kbar).
 - 2) Specifications depend on the drive config.
 - 3) Specifications relate to 400 V/50 Hz.
 - 4) Detailed info in the operating instr.
- [] Specifications apply to alternative equipment.

MOULD INSTALLATION DIMENSIONS | 270 S COMPACT

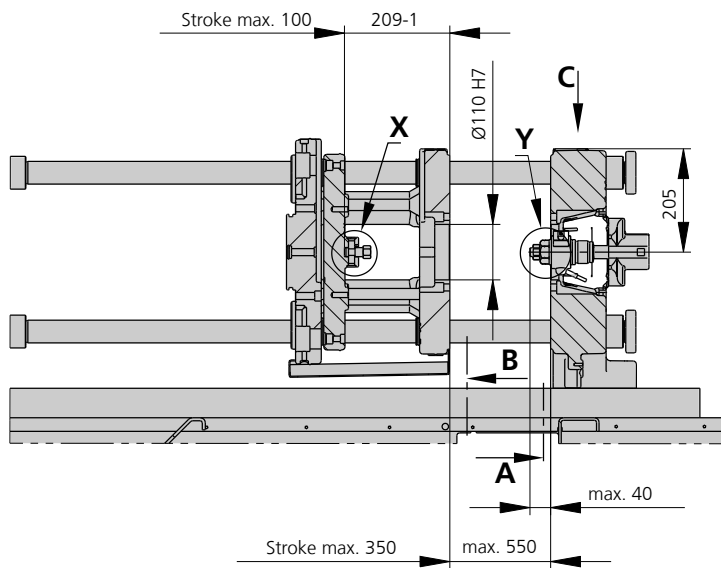

Ejector bolt | X

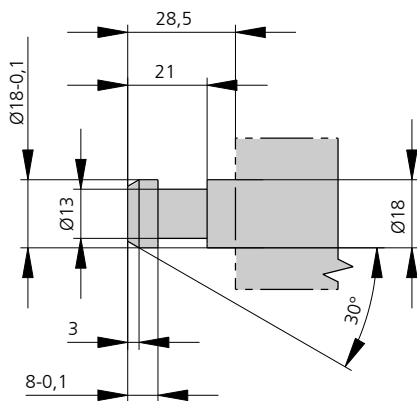

Bore in mould (if required) | Y

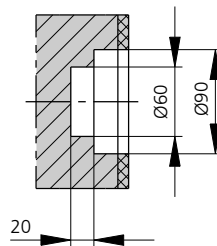

Robotic system mounting | C

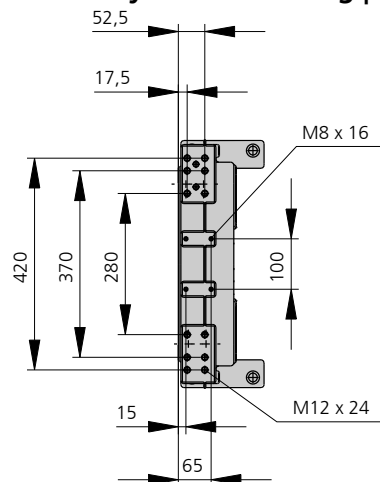

	Injection position of injection unit 100
a min.	55
a max.	185
b min.	70
c min	70

MOULD INSTALLATION DIMENSIONS | 270 S COMPACT

Fixed mould mounting platen | A

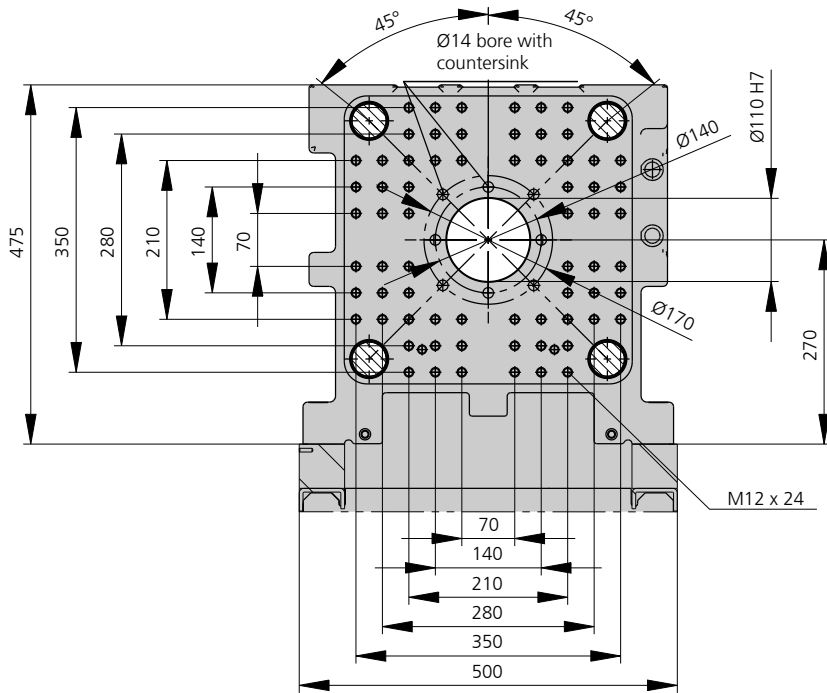

Moving mould mounting platen | B

View D

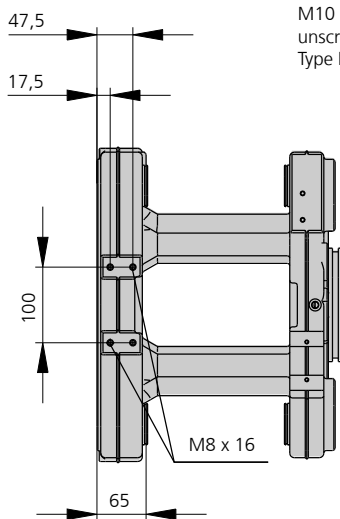

M10 for
unscrewing unit
Type F-AA252

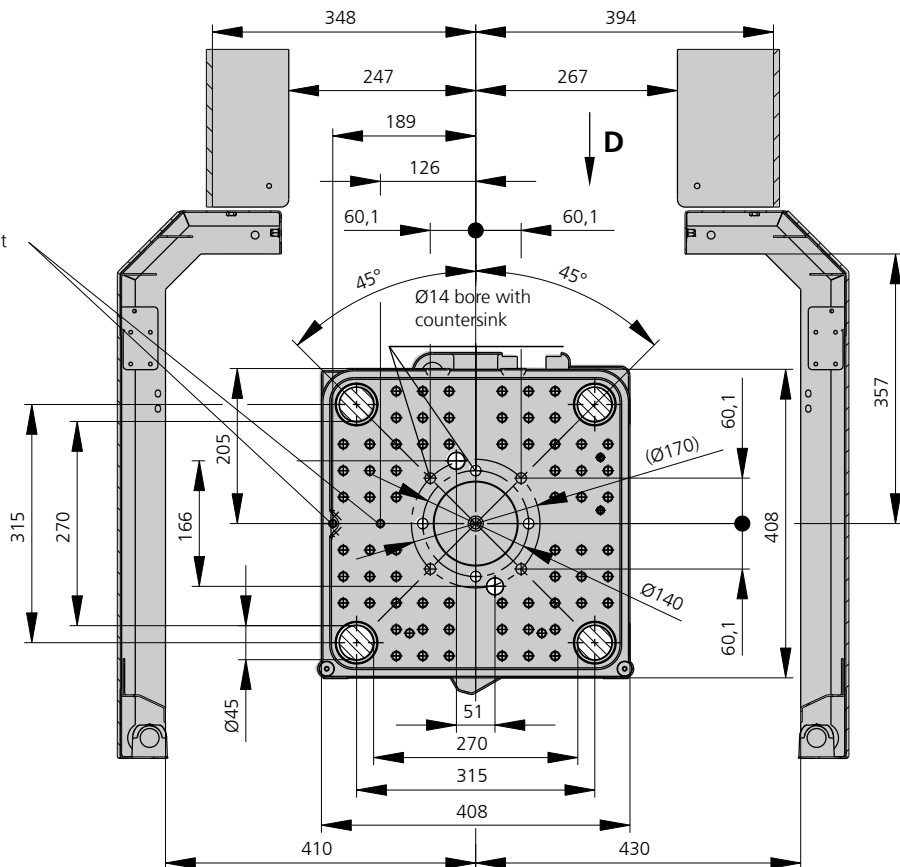

SHOT WEIGHTS | 270 S

Theoretical shot weights for the most important injection moulding materials

Injection units according to EUROMAP		100				
Screw diameter	mm	20	25	30		
Polystyrene	max. g PS	29	45	65		
Styrene heteropolymerizates	max. g SB	28	44	63		
	max. g SAN, ABS ¹⁾	27	43	62		
Cellulose acetate	max. g CA ¹⁾	32	50	73		
Celluloseacetobutyrate	max. g CAB ¹⁾	30	47	68		
Polymethyl methacrylate	max. g PMMA	30	46	67		
Polyphenylene ether, mod.	max. g PPE	27	42	60		
Polycarbonate	max. g PC	30	47	68		
Polysulphone	max. g PSU	31	49	70		
Polyamides	max. g PA 6.6 PA 6 ¹⁾	28	44	64		
	max. g PA 6.10 PA 11 ¹⁾	26	41	60		
Polyoximethylene (Polyacetal)	max. g POM	35	55	80		
Polyethylene terephthalate	max. g PET	34	53	77		
Polyethylene	max. g PE-LD	22	34	49		
	max. g PE-HD	22	35	50		
Polypropylene	max. g PP	23	36	51		
Fluoropolymerides	max. g FEP, PFA, PCTFE ¹⁾	46	72	103		
	max. g ETFE	40	63	91		
Polyvinyl chloride	max. g PVC-U	35	54	78		
	max. g PVC-P ¹⁾	32	50	72		

1) average value

ARBURG GmbH + Co KG
 Arthur-Hehl-Strasse
 72290 Lossburg
 Tel.: +49 7446 33-0
 www.arburg.com
 contact@arburg.com