

# ALLROUNDER 820 A

## Clamp-Design

Distance between tie bars: 820 x 820 mm

Clamping force: 4000 kN

Injection unit (acc. to EUROMAP): 1300, 2100

**ARBURG**

# MACHINE DIMENSIONS | 820 A

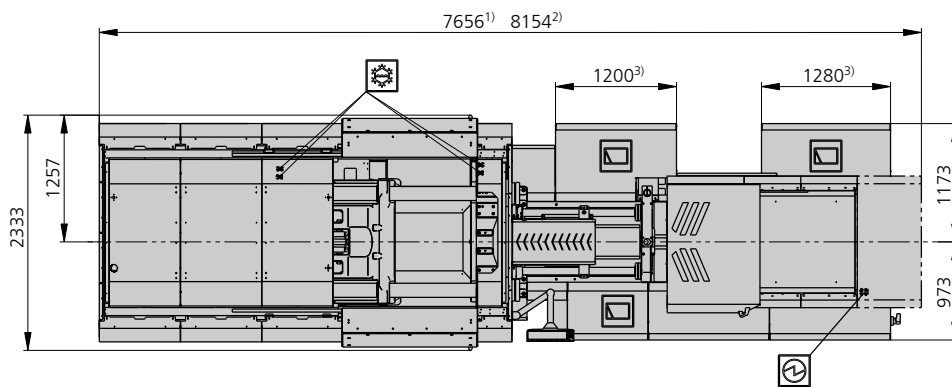
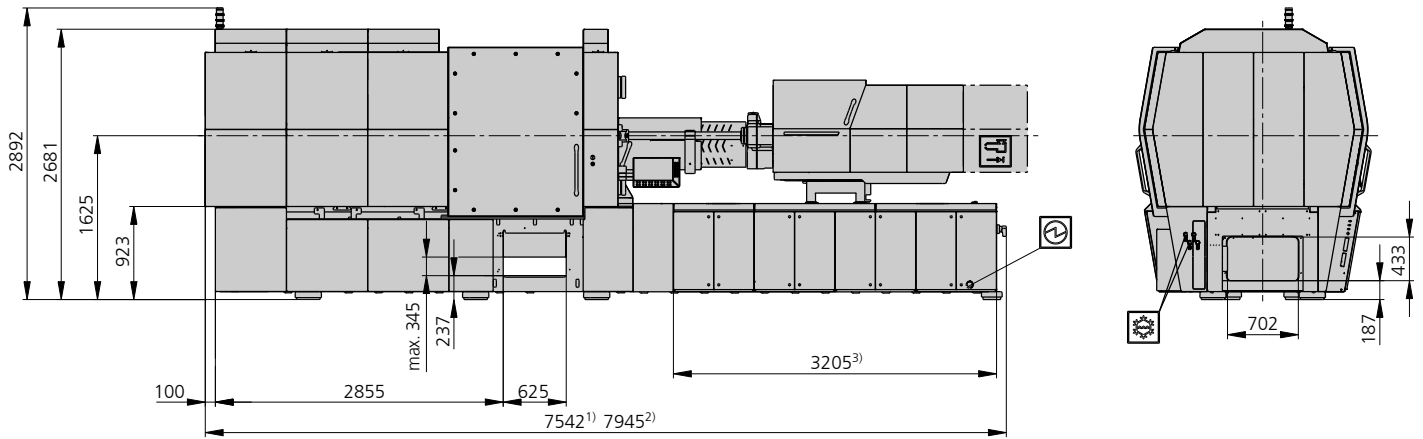

 Electrical connection

 Cooling water connection

- 1) Injection unit 1300
- 2) Injection unit 2100
- 3) Depending on the power and size of the injection unit

# TECHNICAL DATA | 820 A

Clamping unit			820 A
with clamping force	max. kN		4000
Opening force   stroke	max. kN   mm		---   750
Mould height, fixed   variable	min.-max. mm		---   350-850
Platen daylight fixed   variable	max. mm		---   1100-1600
Distance between tie bars (w x h)	mm		820 x 820
Mould mounting platens (w x h)	max. mm		1171 x 1171
Weight of movable mould half	max. kg		4000
Ejector force   stroke	max. kN   mm		86   250
Dry cycle time EUROMAP	Comfort	min. s - mm	2,3 - 574
	Ultimate	min. s - mm	1,8 - 574

Injection unit			1300			2100		
with screw diameter	mm		55	60	70	60	70	80
Effective screw length	L/D		22	20	17	23	20	17,5
Screw stroke	max. mm		240			280		
Calculated stroke volume	max. cm <sup>3</sup>		570	678	923	792	1078	1407
Shot weight	max. g PS		521	620	844	723	984	1286
Material throughput	max. kg/h PS		86	96	115	125	145	175
	max. kg/h PA6.6		43	48	58	62	74	88
Injection pressure	max. bar		2380	2000	1470	2500	2000	1530
Holding pressure time	max. s - bar		300-1900	300-1600	300-1170	300-2180	300-1600	300-1220
Injection flow <sup>2</sup>	Comfort [+]	max. cm <sup>3</sup> /s	261 [356]	311 [424]	423 [577]	339 [452]	462 [616]	603 [804]
	Ultimate [+]	max. cm <sup>3</sup> /s	476	566	772	707 [919]	962 [1251]	1257 [1634]
Injection speed <sup>5</sup>	Comfort [+]	max. mm/s	110 [150]			120 [160]		
	Ultimate [+]	max. mm/s	200			250 [325]		
Screw circumferential speed	max. m/min		55	60	70	51	60	69
Screw torque	max. Nm		1510	1640	1920	2140	2500	2850
Nozzle contact force   retraction stroke	max. kN   mm		90   500			110   600		
Heating capacity   zones	kW		22,9   8			31,2   8		
Feed hopper	l		---			---		

Drive and connection			Comfort		Ultimate	
with injection unit			1300	2100	1300	2100
Net weight of machine	kg		22300	23500	22300	23500
Sound press. level   Insecurity <sup>4</sup>	dB(A)		57   3		57   3	
Electrical connection <sup>3</sup>	kW		70	95	76	100
	Total	A	148	---	142	---
	Machine	A	125	160	125	160
	Heating	A	40	50	40	50
Cooling water connection	max. °C		30		30	
	min. Δp bar		1,5   DN 25		1,5   DN 25	

**Machine type**  
with EUROMAP size designation <sup>1</sup>  
820 A 4000-1300 | 2100

**Upon request: other machine types and mould installation heights, screws, drive powers etc.**

All specifications relate to the basic machine version. Deviations are possible depending on versions, process settings and material type. Depending on the drive, certain combinations, e.g. max. injection pressure and max. injection flow may be mutually exclusive.

- 1) Clamping force (kN) - size of injection unit = max. stroke volume (cm<sup>3</sup>) x max. injection pressure (kbar)
  - 2) Specification of maximum injection flow at maximum injection pressure.
  - 3) Specifications relate to 400 V/50 Hz.
  - 4) Emission sound pressure level at the workplace. Detailed information in the operating instructions.
  - 5) Forward speed of plasticising screw at 1000 bar injection pressure.
- [ ] Specifications apply to alternative equipment.

# MOULD INSTALLATION DIMENSIONS | 820 A

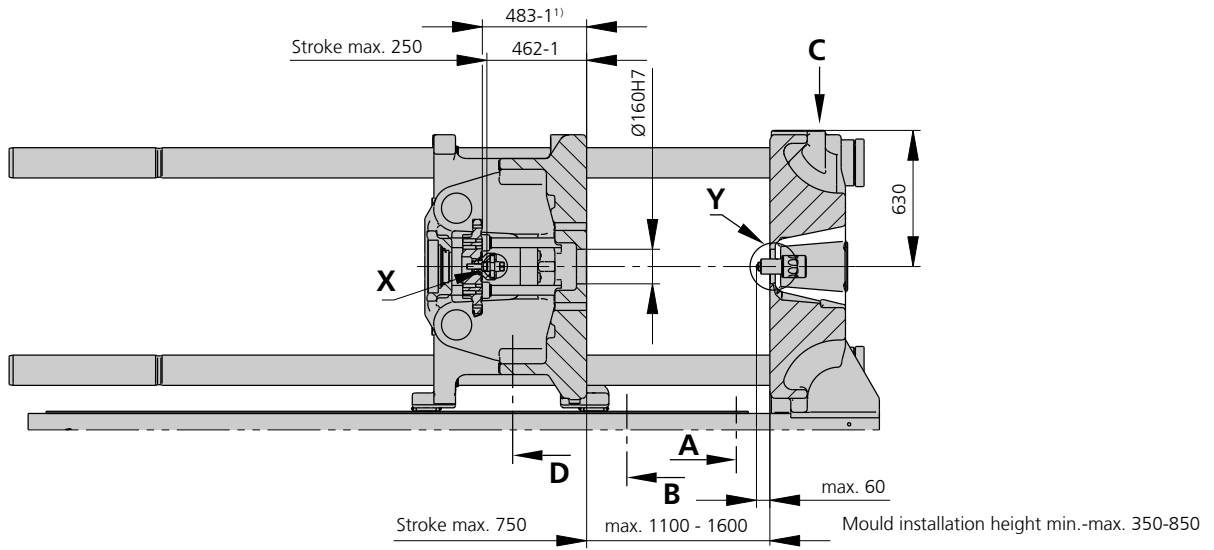

**Ejector bolt | X**

**Bore in mould (if required) | Y**

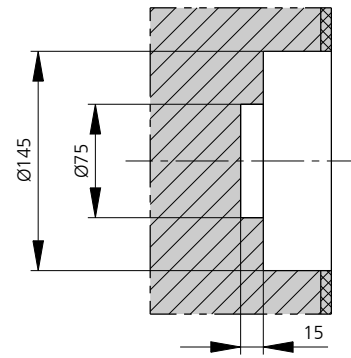
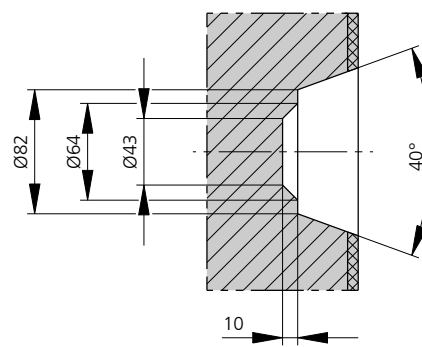
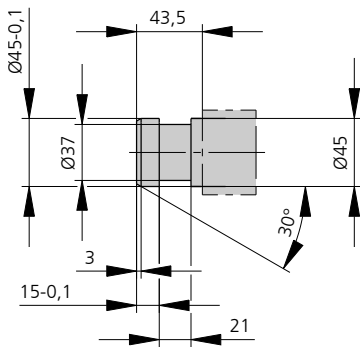

thermoset version -  
injection unit 2100 available on request

**Closing force for spring moulds / during injection compression moulding\***

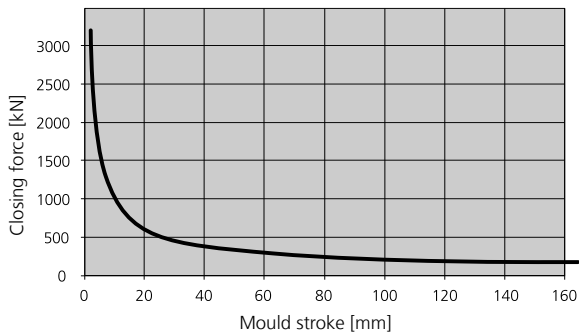

\* automatic locking force adjustment up to 25 kN

**Ejector plate | D**

**Robotic system mounting | C**

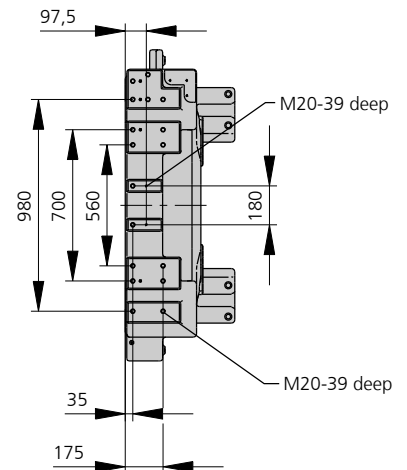
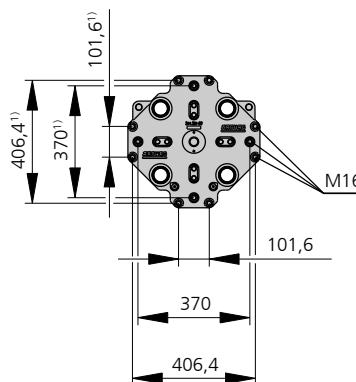

1) Ejector plate position  
Optional: Reinforced mounting platen (see variant 3)

# MOULD INSTALLATION DIMENSIONS | 820 A

## Fixed mould mounting platen | A

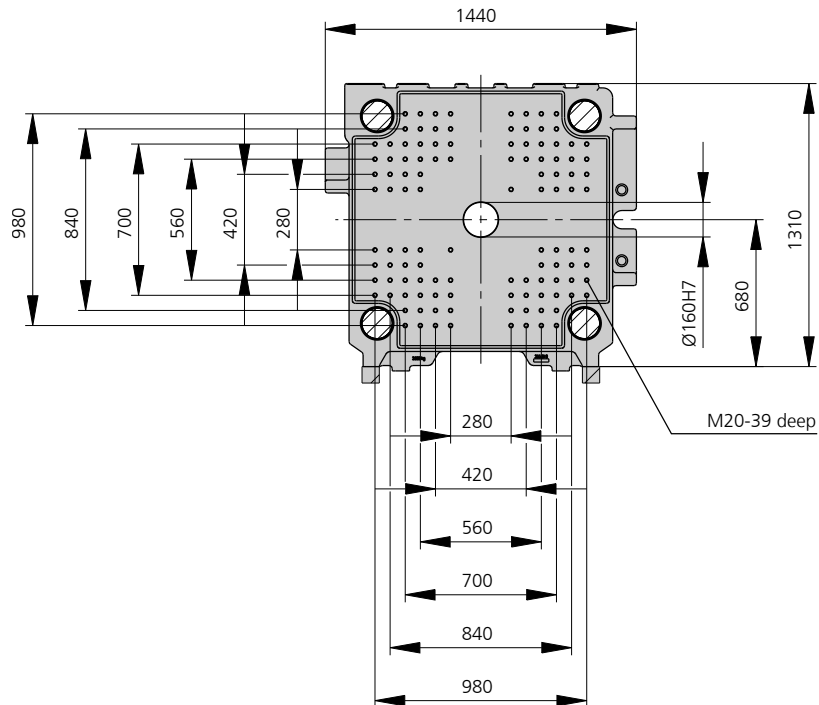

## Moving mould mounting platen | B

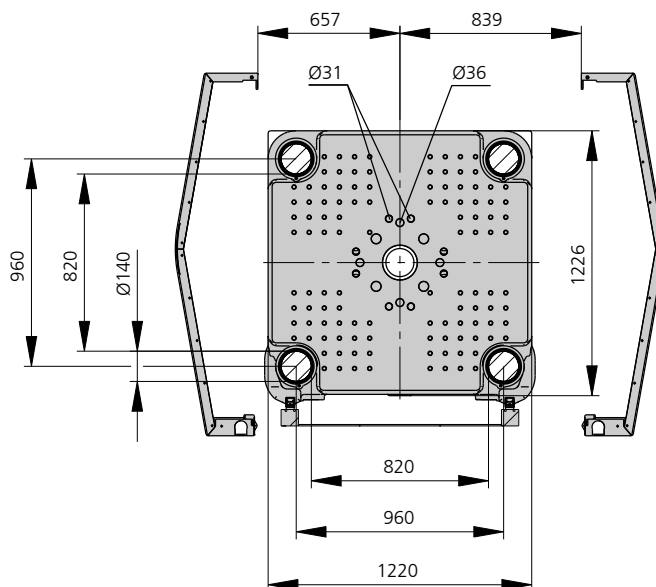

# SHOT WEIGHTS | 820 A

## Theoretical shot weights for the most important injection moulding materials

Injection units according to EUROMAP		1300			2100			
Screw diameter	mm	55	60	70	60	70	80	
Polystyrene	max. g PS	521	620	844	723	984	1286	
Styrene heteropolymerizates	max. g SB	509	606	824	707	962	1256	
	max. g SAN, ABS <sup>1)</sup>	499	594	808	693	943	1231	
Cellulose acetate	max. g CA <sup>1)</sup>	586	698	949	814	1108	1447	
Celluloseacetobutyrate	max. g CAB <sup>1)</sup>	545	649	883	757	1030	1346	
Polymethyl methacrylate	max. g PMMA	538	641	872	747	1017	1329	
Polyphenylene ether, mod.	max. g PPE	484	575	783	671	914	1194	
Polycarbonate	max. g PC	547	651	887	760	1034	1351	
Polysulphone	max. g PSU	566	673	916	785	1069	1396	
Polyamides	max. g PA 6.6   PA 6 <sup>1)</sup>	517	616	838	719	978	1278	
	max. g PA 6.10   PA 11 <sup>1)</sup>	473	575	783	671	914	1194	
Polyoximethylene (Polyacetal)	max. g POM	643	765	1042	893	1215	1588	
Polyethylene terephthalate	max. g PET	620	738	1005	861	1172	1531	
Polyethylene	max. g PE-LD	393	468	637	546	744	971	
	max. g PE-HD	406	483	658	564	768	1003	
Polypropylene	max. g PP	415	494	672	576	784	1025	
Fluoropolymerides	max. g FEP, PFA, PCTFE <sup>1)</sup>	834	992	1350	1157	1575	2058	
	max. g ETFE	731	870	1185	1015	1382	1805	
Polyvinyl chloride	max. g PVC-U	629	749	1020	874	1190	1554	
	max. g PVC-P <sup>1)</sup>	582	692	942	808	1099	1436	

1) average value

**ARBURG GmbH + Co KG**  
 Arthur-Hehl-Strasse  
 72290 Lossburg  
 Tel.: +49 7446 33-0  
 www.arburg.com  
 contact@arburg.com