

MICRO-INJECTION MODULE

Machine size: 270-370

Injection unit (acc. to EUROMAP): 70

ARBURG

TECHNICAL DATA | MICRO-INJECTION MODULE

Pre-plasticising

Screw diameter	mm	15 18
Effective screw length	L/D	11
Material throughput ¹	max. kg/h PS	1,0 1,4
	max. kg/h PA 6.6	0,5 0,7
Circumferential screw speed	max. m/min	5,4 6,5
Screw torque	max. Nm	30
Installed cylinder heating power/heating zones	W	1570 / 4
Installed nozzle heating power	W	100
Approved cylinder temperature	max. °C	450
Material hopper capacity ²	l	1,8

Injection screw

Screw diameter	mm	8
Effective screw length	L/D	12
Calculated injection volume	cm ³	2,5
Shot weight	max. g PS	2,3
Injection pressure	max. bar	2000
Holding pressure	max. bar	2000
Injection flow	max. cm ³ /s	15
Circumferential screw speed	max. m/min	13
Screw torque	max. Nm	10

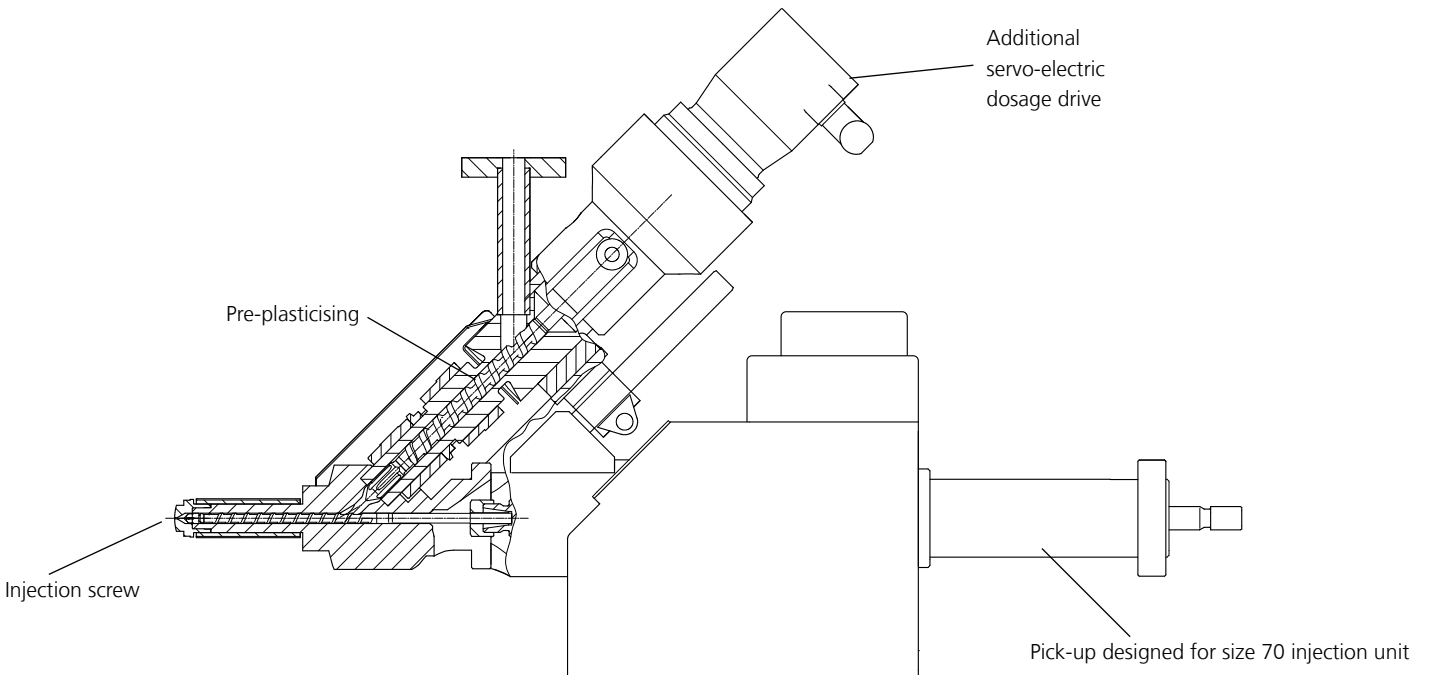

1) Deviations are possible depending upon process settings and material type
 2) Optional

The technical data is correct at the time of printing. We reserve the right to make changes in the interests of continuous development.

EQUIPMENT | MICRO-INJECTION MODULE

The requirement for the use of the micro-injection module is an electric ALLROUNDER A (size 270 or 370) with size 70 injection unit

- Micro-injection module as a self-contained module with central coupling
- Highly wear resistant version
- Open nozzle with screw-in tip
- Heated nozzle tip
- Material hopper, 1.8 litres

- Machine prepared for micro-injection module:
 - Injection unit guarding with safety gate monitored on one side (operator side)
- Connection for servo motor on the rear of the machine for actuating the dosage drive on the micro-injection module

- Pressure measuring channel on the rear of the machine – permanently configured for micro-injection module
- SELOGICA functional expansion: pressure control for pre-plasticising

- Basic machine
- Options

ARBURG GmbH + Co KG

Arthur-Hehl-Strasse
72290 Lossburg
Tel.: +49 7446 33-0
www.arburg.com
contact@arburg.com