



# PRODUCTS AND SERVICES

Efficient plastics processing  
"Made by ARBURG"

**ARBURG**

# PIONEER

Technology, expertise, service –  
we always give our best for you!

Our aspiration is: To be your technology and system partner! In every respect. Whether injection moulding or industrial additive manufacturing. Whether stand-alone machine or highly automated turnkey system. Whether process control or comprehensive digital data management – including cloud-based solutions. Regardless of the industry you are involved in, the processes you use, or the parts and unit volumes you want to manufacture. Our modular product portfolio has the right solution for all your requirements. We do our utmost to meet your efficient plastics processing needs.

**WIR SIND DA.**



Wide range: We offer you machines with clamping forces from 125 to 6,500 kN.

# THE REFERENCE FOR INJECTION MOULDING TECHNOLOGY: ALLROUNDERS

// Why should you trust in our ALLROUNDERS? Because you can rely on the best that is available when it comes to injection moulding technology. From small to large. From conventional to vertical configurations. From performance versions to high-speed machines. From systematically standardised general-purpose machine series to machines customised for specific processes. Our product range is oriented specifically to your requirements. The choice is yours: just the way you want it! //

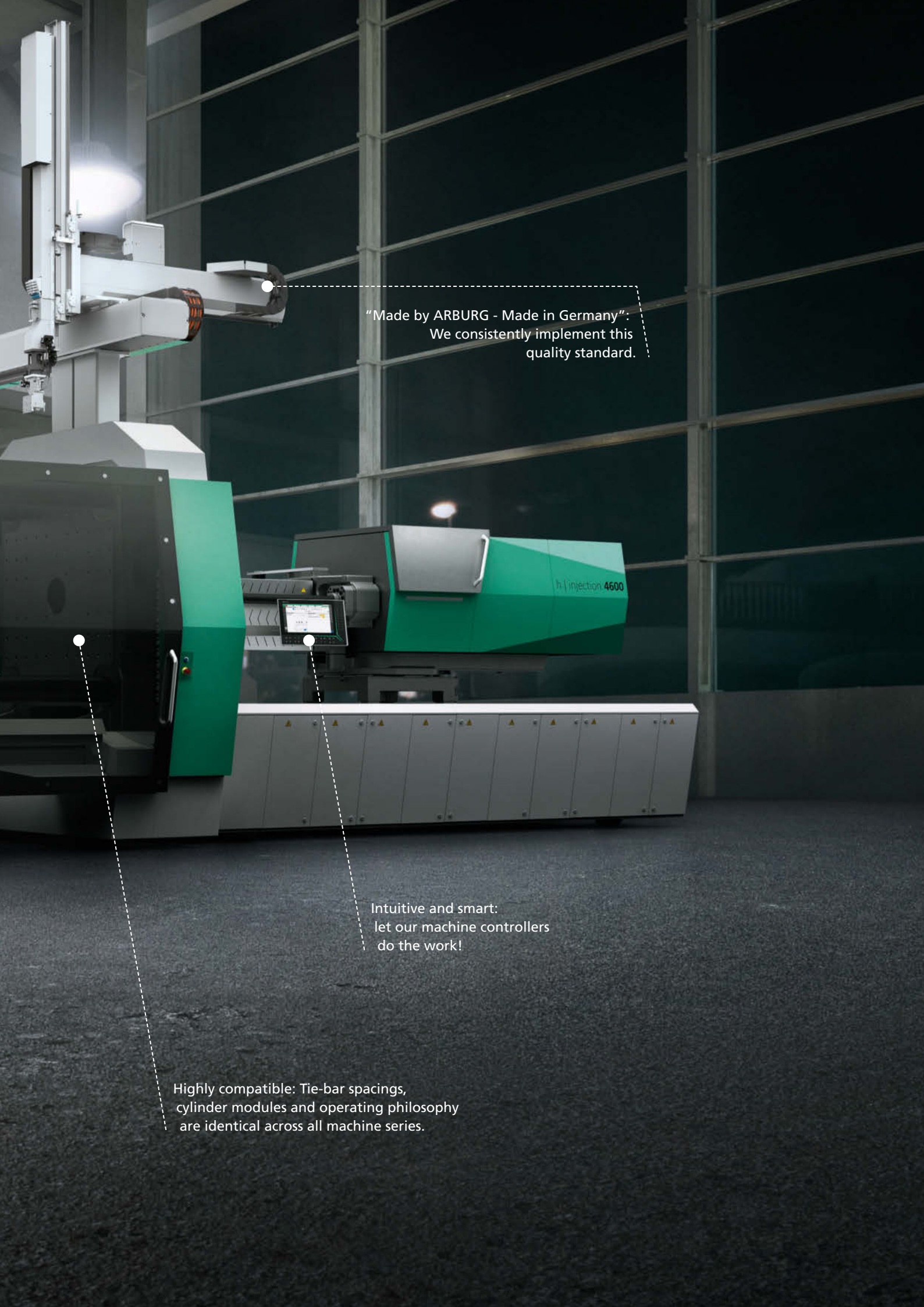

“Made by ARBURG - Made in Germany”:  
We consistently implement this  
quality standard.

Intuitive and smart:  
let our machine controllers  
do the work!

Highly compatible: Tie-bar spacings,  
cylinder modules and operating philosophy  
are identical across all machine series.

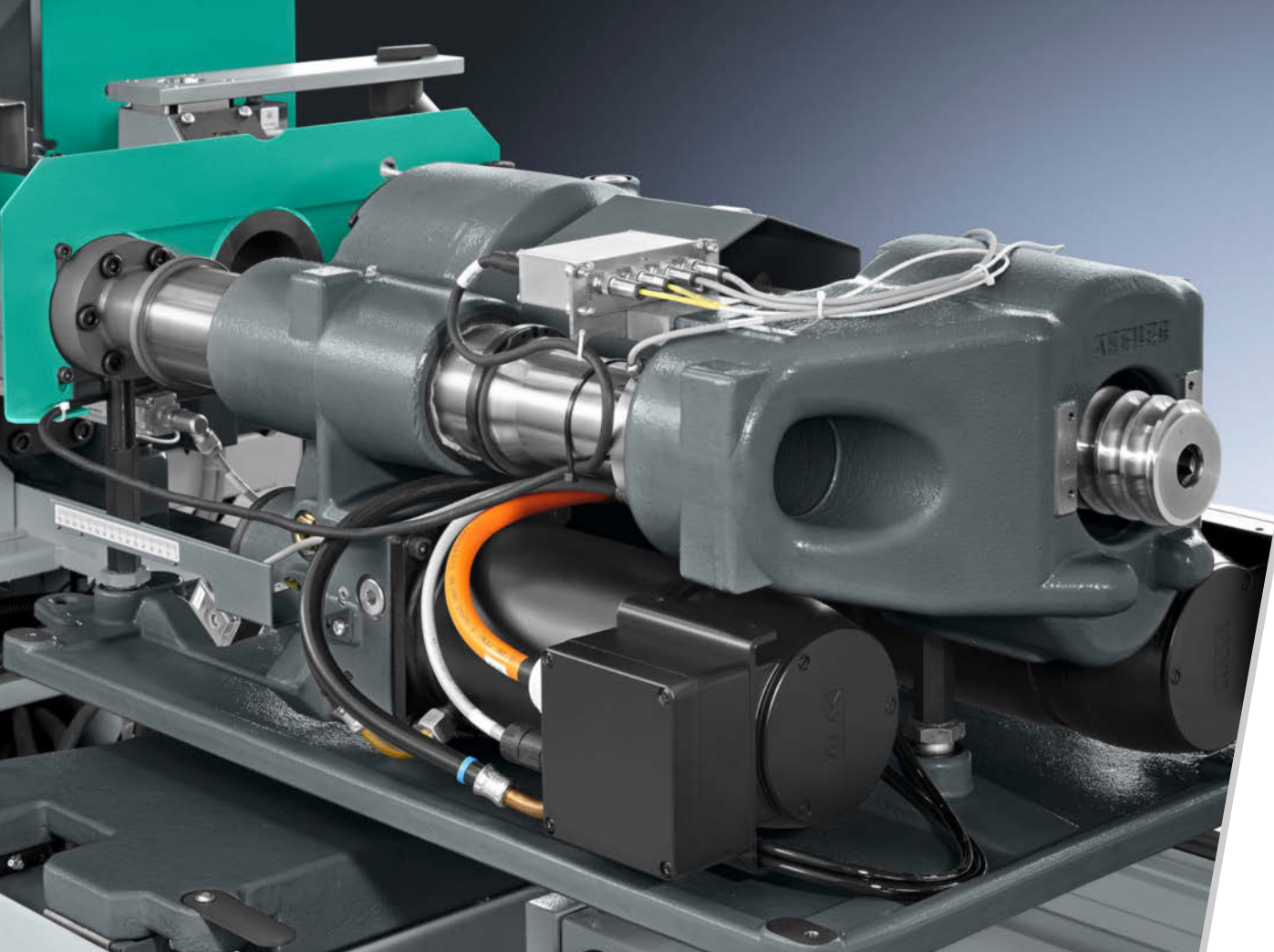

# PROFIT-ORIENTED: ELECTRIC ALLROUNDERS

// Cost-effective performance that's simply outstanding: with a perfect spectrum of machine dimensions available, our electric machines are suitable for all of your applications. The GOLDEN ELECTRIC is our standardised general purpose machine series at an unbeatable price. To accommodate more demanding equipment requirements and more challenging production tasks, our ALLDRIVE offers the features you need. Choose your electric ALLROUNDER from one of the most comprehensive ranges in the industry. //

**i** // Further information:  
Electric ALLROUNDER brochure

## Speed

Injection, dosing and opening and closing of the mould are servo-electrically driven as standard on GOLDEN ELECTRIC and ALLDRIVE machines – allowing fully independent operation. Fast acceleration and speeds, as well as simultaneous movements, enable high-speed cycles.

## Energy efficiency

The toggle-type clamping unit, the high efficiency of the servo-electric drives, as well as the recovery of braking energy form the basis for high energy efficiency. The energy requirement is reduced by up to 50 percent.

## Precision

Direct spindle gears ensure mechanically rigid drives and dynamic movements. The excellent positioning accuracy of servo-electric drives permits maximum reproducibility and part quality.

## Value

The high degree of reliability of the machines and subsequent minimal variability in the process is achieved through many technical details. This includes, for example, the closed cooling circuit of motors and converters for fast cycles and long holding pressure phases.

## Minimising emissions

The liquid-cooled drives operate quietly without air turbulence and reduce emissions into the environment. Closed drives and spindle systems prevent exposure to dust caused by abrasion. Perfect conditions for use in pure production environments.

Uncompromising high-end technology: Servo motors are generally liquid-cooled.

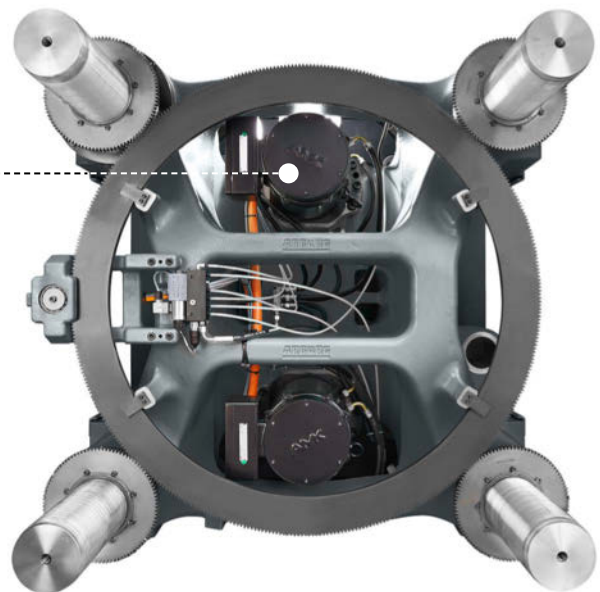

Compared to the hydraulic standard up to

**50 %**  
**ENERGY SAVING**

---

Distance between tie bars: **270 - 1120 mm**

---

Clamping forces: **350 – 6,500 kN**

---

Injection units: **5 - 2100**

---



Flagship ALLROUNDER 1120 H: Its attractive and highly functional design will be progressively implemented on further machines.

Distance between tie bars:	<b>270 - 1120 mm</b>
Clamping forces:	<b>350 – 6,500 kN</b>
Injection units:	<b>70 - 7000</b>

# HIGH PERFORMANCE: HYBRID ALLROUNDERS

// If you are interested in high performance during the production of mass-produced technical parts, then you should work with our hybrid ALLROUNDERS. This is because the HIDRIVE brings the best of our modular product range together in a single series just for you: Electric speed and precision paired with hydraulic power and dynamics. Reliable, highly-productive and simultaneously energy-efficient – for your production. Day after day. 24 hours. Around the clock. //



Further information:  
Hybrid ALLROUNDER brochure



# WITH OUR MODULARITY, YOU KEEP YOUR UNIT COSTS UNDER CONTROL.

## Production capacity

The hybrid ALLROUNDER machine concept has been configured with the particular aim of achieving high production capacities. It brings together the servo-electric clamping units of the ALLROUNDER A and generously dimensioned injection units with hydraulic accumulator technology. All movement axes operate completely independently of one another.

## Energy optimization

The servo-electric drives for mold movement and dosing as well as the recovery of braking energy form the basis for high energy efficiency. Moreover, the hydraulic drive operates with a performance-adapted pump and an efficiency class IE3 electric motor.

## Cycle time reduction

Simultaneous movements combined with extremely short dry cycle times of the servo-electric clamping units enable fast cycles. Special features such as "injection on the fly" while the mould is closing or dosage that takes place across several cycles are also available.

## Dynamics

As well as the servo-electric toggle, the hydraulic accumulator technology also reduces cycle times. This enables large, dynamic injection volume flows to be achieved. At the same time, the aXw Control ScrewPilot ensures reproducible injection and, hence, high part quality.

## Cost-efficiency

The sophisticated hybrid ALLROUNDER technology is synonymous with reliable operation and maximum availability. In addition, technical detailed solutions minimise the set-up and maintenance effort. This also makes day-to-day production much more efficient.

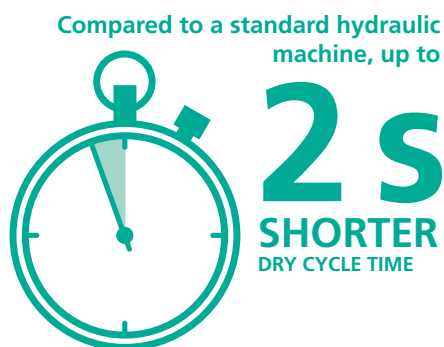

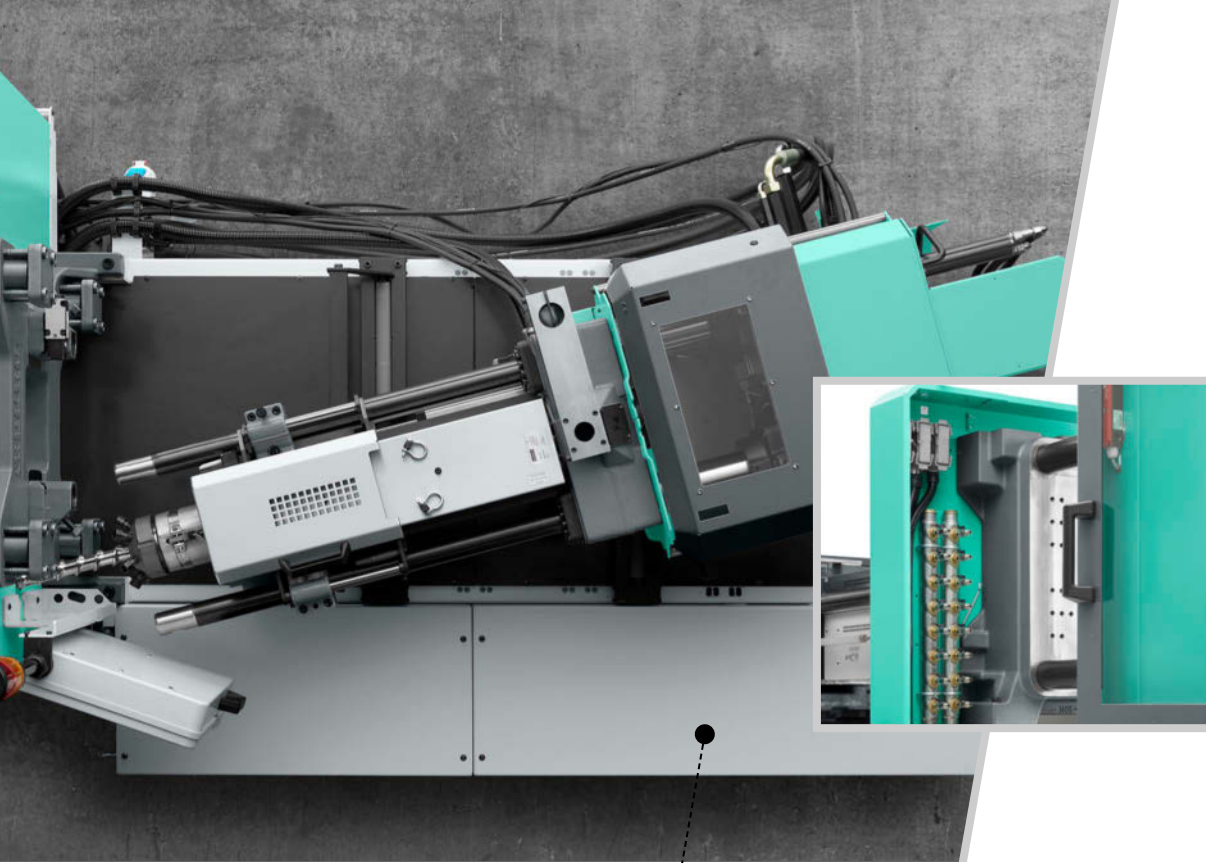

Practical relevance in every detail:  
Our sophisticated technology offers  
you all the freedom required for  
efficient operation.

## EXEMPLARY: HYDRAULIC ALLROUNDERS

// Reliable, proven injection molding technology „Made by ARBURG – Made in Germany“: This is what our hydraulic machines stand for. With the ALLROUNDER principle, differential piston system, and ScrewPilot, we have been setting standards since 1961. Our products range from the low-cost GOLDEN EDITION general-purpose machine series to flexible, adaptable ALLROUNDER S machines. Our modular structure offers you process-optimized solutions with low operating costs and the greatest possible variety of applications. Simply tell us your requirements and we will configure a suitable ALLROUNDER especially for you. //

---

Distance between tie bars: **170 - 920 mm**

---

Clamping forces: **125 – 5,000 kN**

---

Injection units: **30 - 4600**

---

**i** Further information:  
Hydraulic ALLROUNDER brochure

## Diverse applications

Our machine concept is extremely flexible and can be precisely adapted for operation in conjunction with all familiar injection moulding processes. This is ensured by numerous equipment and configuration options. For example, the ALLROUNDER S can

- use swivelling clamping units to overmould inserts (ALLROUNDER principle).
- work with an interchangeable injection unit in the mould parting line.
- fill the mould in a linear action using a horizontally free-sliding injection unit (VARIO principle).

## Individuality

The power of the drive technology can be individually adapted. Multiple hydraulic variants and electrical configuration levels allow you to achieve greater energy efficiency, higher precision and speed - just as your application demands.

## Cost efficiency

The GOLDEN EDITION is our hydraulic general-purpose machine series. Our recipe for success: the use of proven, uncompromising high-end technology, standardised at an unbeatable price. Two-circuit pump technology is provided as standard for example.

## Reproducibility

Regulated injection ensures the customary high part quality. Our unique aXw Control ScrewPilot can therefore be used to achieve dynamic and reproducible injection that is on a par with electric machines.

## Reliability

Optimum availability and a long service life are synonymous with the ARBURG name. Examples include energy-saving oil displacement via the differential piston system of the clamping unit, or the scratch-proof powder enamel coating of the machine components.



# SIMPLY PRACTICAL: VERTICAL ALLROUNDERS

// Clearly: Much of the focus with our vertical ALLROUNDER machines is on efficiency in practice. This calls for dependable, process-reliable and precise operation. But above all, they must be one thing: Ergonomic. This ensures that cooperation between human and machine is a comfortable experience. Our versatile vertical product range is fully focused on the overmoulding of inserts and offers you all the features required to help you manage your specific tasks. //

Vertical free-space system of the ALLROUNDER V: Perfect for both manual and automated part feed systems.



Automated part feed system:  
Our rotary table machines ensure high productivity.

Ideal for manual operations:  
The low table heights of our vertical ALLROUNDERS.

 Further information:  
Vertical ALLROUNDER brochure

## Ergonomics

Efficient overmoulding of inserts? This means organising manual work in a comfortable and time-saving manner. This is precisely the purpose of our vertical free-space system on the ALLROUNDER V: It provides unimpeded access to the mould when inserting and removing items.

## Process reliability

High-quality plasticizing and molded parts: The special aXw Control ScrewPilot makes reproducible injection possible in the same way as on electric machines. The servo-electric rotary tables of the ALLROUNDER V and T operate energy-efficiently, quickly and precisely.

## Application suitability

The right technology for every application. We achieve this thanks to:

- A wide range of designs, machine sizes and injection units
- Vertical and horizontal arrangement of the injection units
- Task-specific equipment, such as for silicone processing

## Space optimisation

Especially our ALLROUNDER V machines impress with their compact design and small footprint. This makes the machines ideal for use, even in confined production environments. The scope for planning the installation of the machines remains correspondingly high.

## Automation

Shorter cycle times and higher productivity: Rotary and shuttle tables are available to enable simultaneous insertion and removal during the injection process. Versatile configuration options ensure that the machines can also be very easily integrated in turnkey systems.



---

Variety of clamping systems

---

Clamping forces: **125 – 4,000 kN**

---

Injection units: **30 - 2100**

---

Further special sizes and injection units available on request.

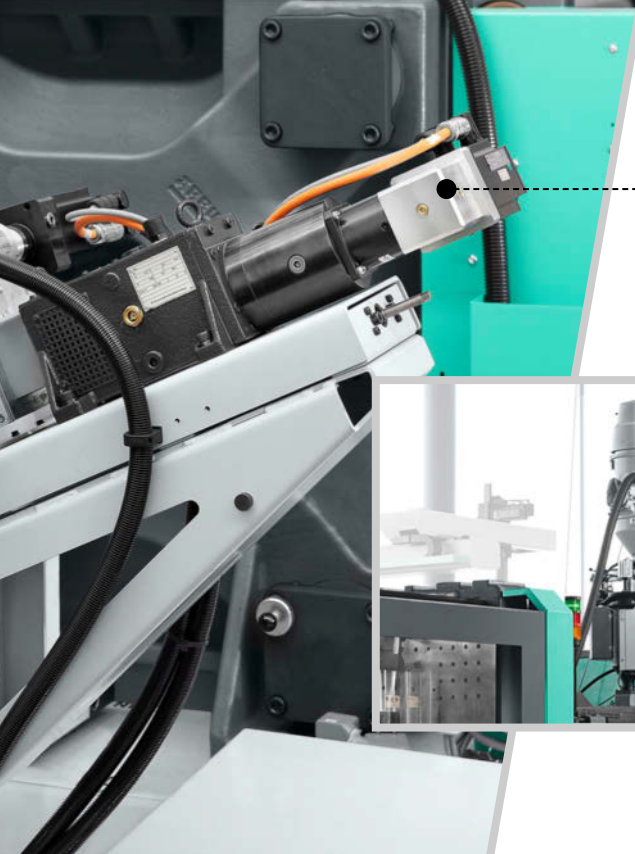

Precise coordination:  
e.g. lightweight construction  
for Fibre Direct Compounding  
or foaming with ProFoam.

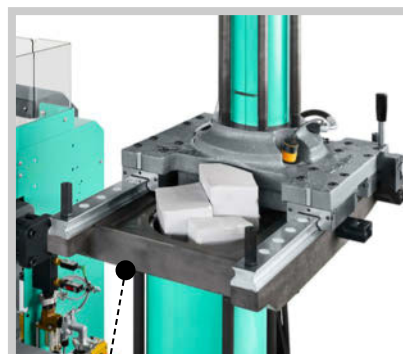

Material compatible: e.g. processing  
solid silicone (HTV) or moist polyester  
(BMC) with INJESTER tamping device.

## PERFECTLY COMPATIBLE: THE ADDITIONAL EQUIPMENT

// Our machine technology is completed by flexible additional equipment, with which you can adapt your ALLROUNDERS individually to the relevant production requirements and injection moulding process. Modular design, simple operation and complete integration are a matter of course for us. The same applies to comprehensive application technology consulting.

Our aspiration is to support you in every aspect.

To ensure that you can do one thing without fail: Produce efficiently! //

### Outstanding support

- Machine and process technology consulting
- Assistance with moulded part and mould design
- Support during in-depth trials and tests

**i** Further information:  
Application expertise brochure  
THERMOLIFT brochure

# ” EVERYTHING POSSIBLE IN TERMS OF PROCESS ENGINEERING WITH US. “

## Application expertise

You couldn't ask for more! To find the best solution for you, we provide well-founded expertise in all facets of injection moulding and special additional equipment e.g. for

- Multi-component injection moulding
- Injection moulding of silicones, elastomers, thermosets and metal or ceramic powders
- Injection moulding of lightweight parts through foaming processes, Fibre Direct Compounding (FDC) and thermoplastic composites
- Working under clean-room conditions
- Micro injection moulding
- Injection compression moulding
- Overmoulding of inserts

## Peripheral equipment and accessories

The individual expansion of your ALLROUNDER does not end with process technology, however. In terms of peripheral equipment and accessories, we offer efficient options:

- THERMOLIFT granulate dryer and conveyor – compact unit for installation close to the machine, with which two ALLROUNDERS can be fed.
- Unscrewing units for precise demoulding of external and internal threads in moulded parts – optionally available in various versions.
- Rapid clamping systems for simple, fast and reliable mould changes.





Integrated: We automate operations upstream and downstream of the injection moulding process.

# PRIMARY CONTRACTOR ARBURG

// Machine, robotic system, peripheral equipment, process control, data management – we relieve you of the planning and implementation of demanding production tasks. You have just one point of contact, one order and one delivery date for your project. As a technology and system partner, we assume overall responsibility. And you can concentrate on what's essential: Your customers. //



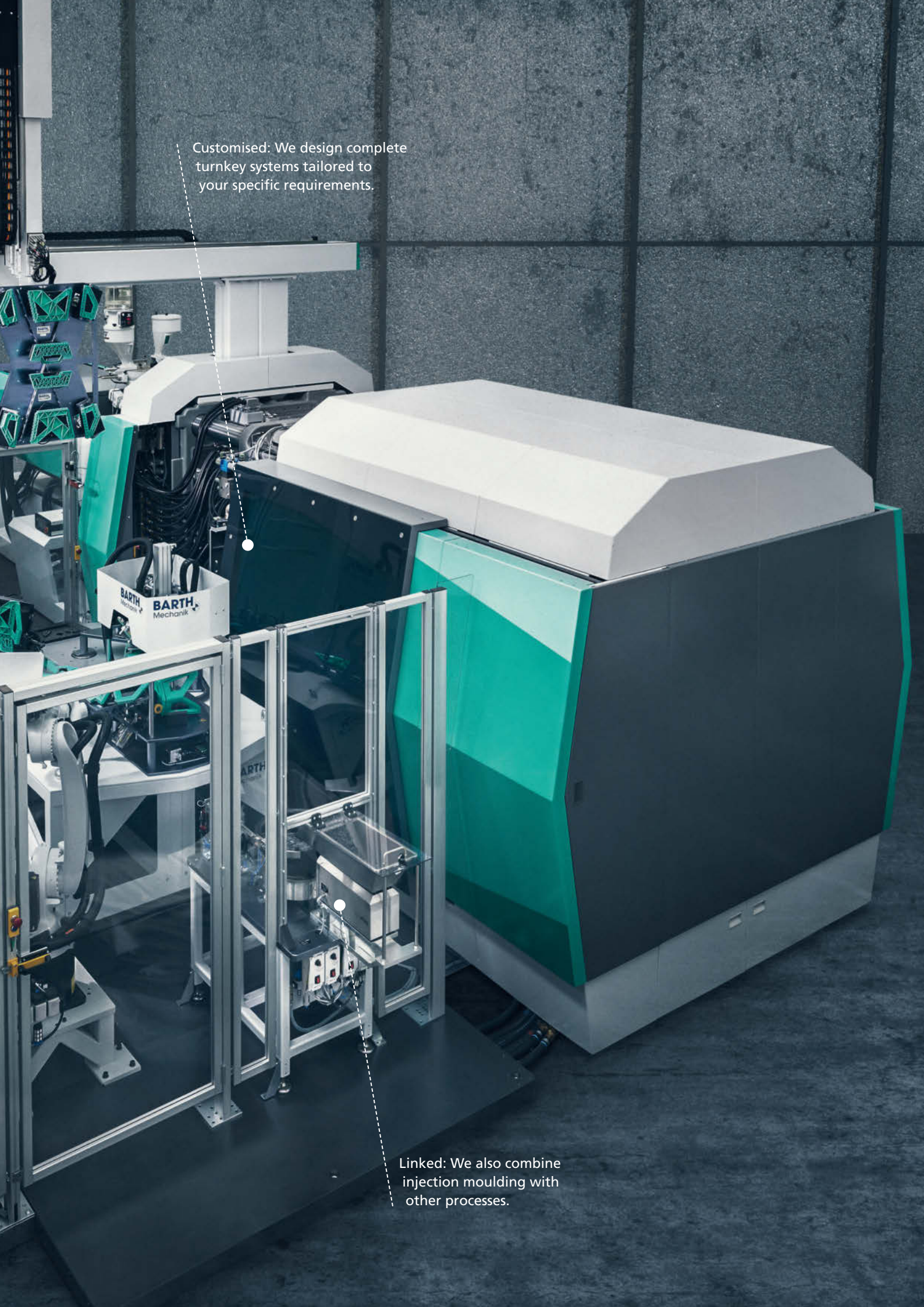

Customised: We design complete turnkey systems tailored to your specific requirements.

Linked: We also combine injection moulding with other processes.



# FACILITATORS: ROBOTIC SYSTEMS

// Productivity and reliability really count. That's why our ALLROUNDER machines and robotic systems work hand in hand. Adapted to your specific requirements. Precise, fast and reliable. Integrated complete solutions that allow you to start production directly. We make everything possible. This is thanks to a broad product range and extensive integration with which you can centrally manage and synchronously control processes. This is the only way to ensure highly efficient and cost-effective robotic technology. //

**i** / Further information:  
Robotic systems brochure

---

Various robotic systems

---

Handling weights: **1 - 120 kg**

---

## Plug and work

Space-saving design and fast production readiness: The ALLROUNDER and robotic system form a fully functional CE-certified unit. As a primary contractor, ARBURG guarantees perfectly coordinated interfaces and safety features – both mechanical and electrical.

## Flexibility

Can you coordinate robotic technology precisely to every handling task? Yes, you can! Our product range extends from a simple picker to versatile linear robots and multi-functional multi-axis robots. Moreover, various designs and special versions with practical configuration options are also available in terms of size, axes, axis drives and lengths. Also available: Extensive interfaces for gripper and peripheral technology. Greater flexibility is not possible.

## Cost-efficiency

Top quality and performance: We also implement these principles consistently with our robotic systems. The robust, low-maintenance technology ensures a long service life and high availability. Extensive integration simplifies set-up and reduces mould-entry times.

## Ease of use

As with ALLROUNDERS, robotic systems can be configured using typical ARBURG sequence programming. The signal exchange goes well beyond the range of functions of a Europmap interface. This has clear benefits for you:

- One data set – no adaptation required
- Synchronous process control - short cycle times
- Assistance functions – easy set-up, fast start-up
- Low training requirement - same approach for all machines

100.000.000  
KILOMETER

legen Robot-Systeme von  
ARBURG pro Jahr zurück



Fully compatible: Standardised operating system reduces training and set-up requirements.



# UNIQUE: TURNKEY PROJECTS

// Looking to further increase added value with regard to your injection moulding process? We can offer you the wide-ranging expertise for the automation and integration of even complex process steps. Several hundred individual turnkey systems go into operation each year, with ARBURG acting as the primary contractor and covering all aspects, from design to cycle-time optimisation. Just tell us your production task and we'll take care of it. Professionally and reliably - just as you'd expect from us. //

A great deal is possible:  
Automated process steps  
increase production efficiency.



Interdisciplinary teamwork:  
We generate synergy effects for  
individual project concepts.

**i** / Further information:  
Turnkey projects brochure

# OUR EXPERTISE OFFERS YOU ADDED VALUE.

## All-round carefree package

Our turnkey experts are called in whenever operations need to be integrated upstream and downstream of the injection moulding process. We assume overall responsibility as “architects” of your turnkey system. Services range from individual design, the definition of interfaces, as well as the coordination and monitoring of the entire project, from procurement to commissioning. This all-round carefree package continues seamlessly in our range of services. Here too, we act as a point of contact that takes care of all aspects.

## Comprehensive project management

We always provide the best turnkey solutions because we network at an interdisciplinary level in brainstorming teams. This gives you access to our extensive expertise. System concepts are developed together with you and always follow the “second pair of eyes principle”. Discussing all issues as a team ensures maximum creativity and confidence in realising all your tasks. We deliver your complete turnkey system on the date agreed with you. Because these are pre-tested and the sequences are optimised, they can quickly go into production.

## A local presence, worldwide

Our position within the market, size and global presence make us a reliable partner the world over. We provide not only local sales and service, but also turnkey experts who design production cells tailored to your market and realise them with local partners. This has several benefits for you: No language barriers exist and physical proximity enables faster processing of inquiries.

We are technology and system partners for automated production cells with more than

25



YEARS  
OF EXPERIENCE



Discharge units:	<b>2 - 3</b>
Build area:	<b>200 - 300 cm³</b>
Part carrier:	<b>3-axis</b>

# SHIFT WORKER: freeformer

// We are completely redefining plastics processing with our patented process for industrial additive manufacturing, known as ARBURG Plastic Freeforming (APF). The freeformer, our open system for the additive manufacturing of functional parts, produces efficiently and flexibly. Parts created directly from 3D CAD data. Using qualified standard granulates. Layer-by-layer application of tiny plastic drop-lets. Get started with a technology that offers brand new opportunities to produce one-off parts and small-volume batches. //

- freeformer – more than just 3D printing**
- Additive manufacturing with standard granulates
  - Individual process settings and material qualification
  - High part quality
  - Technical functional parts – also as hard/soft combinations

**i** Further information:  
freeformer brochure

## Material diversity

The freeformer can be used to process standard granulates in a flexible way. It does not require any prefabricated materials such as resins, powders or filaments. This means that a wide range of low-cost materials and dyes are available to choose from. However, reproducible additive manufacturing requires the materials used to be qualified in a standardised process. This results in pre-defined process settings, which we make available to you for reference materials. We are continuously expanding this database. In addition to the familiar additive standard materials, you can also process special original materials using our freeformer. These include, for example, TPEs with various Shore hardnesses, semi-crystalline PP, biopolymers, flame-proof materials and medical-grade polylactide.

## Open system

The freeformer is designed as an open system. Slice and process parameters are freely programmable and can thus be individually adapted at any time. Based on our data sets for reference materials, your modified original materials are quickly available for use, as was the case with a PC approved for aerospace applications or an FDA-compliant medical-grade TPE.

## Multi-component technology

The freeformer is equipped with several discharge units as standard. You can use these to produce parts in various material and colour combinations – also as resilient hard/soft combinations. In the case of complex part geometries, you can alternatively use one component to construct support structures.

**DROPLET** BY  
**DROPLET**  
into  
functional parts



# EFFICIENCY DRIVER: arburgXworld

// Digitalisation means becoming more efficient – at every point along the entire value chain. Starting with machine purchasing and order planning, production and quality assurance through to maintenance and spare parts purchasing. This is where the world of our digital networking comes in. Our arburgXworld will support you in all aspects. Join us on the path to your smart factory and increase your competitiveness on a sustainable basis. //

## This is what our arburgXworld means for you

- Comprehensive expertise
- Integration of production and information technology
- Assistance tools for control systems
- Online data management
- Platform for digital services

## Individual strategy required

Our aspiration is: We are your technology and system partner, especially when it comes to digitalisation! You will benefit from our extensive expertise and individually combinable components. Come and join our arburgXworld!



Further information:  
arburgXworld brochure









### **Smart machine: Assisting and controlling**

Operators need to be able to adjust and control production processes intuitively, however complex they may be. This calls for a smart machine that offers extensive data integration options, monitors and adaptively controls your processes, and supports you in every operating situation. This is exactly what the connectivity modules and assistants of our SELOGICA and GESTICA control systems are designed to do.

### **Smart production: enter data online**

Reliable documentation with no effort or incorrect entries. Directly available feedback and key indicators for the management level – even mobile! Detailed planning down to the minute to optimise capacity utilisation, quality and delivery reliability. With regard to IT networking in production, our ARBURG host computer system (ALS), which is specially tailored to injection moulding companies, plays a key role. Turning big data into smart data.

When it comes to one hundred per cent traceability of interlinked work steps in production cells, we also have a solution for you. Our ARBURG Turn-key Control Module (ATCM) collects relevant process and quality data on a part-specific basis and forwards them to an evaluating system.

**i** / Further information:  
GESTICA brochure  
Host computer system brochure



Order spare parts online: with our arburgXworld customer portal it's easy to do so around the clock.

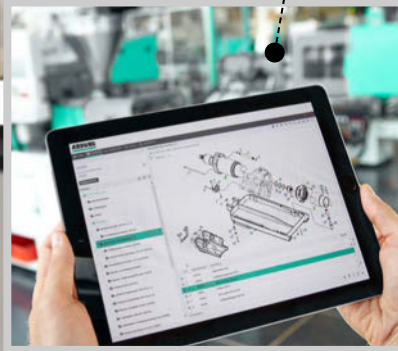

## Smart services: Rethinking work

Our arburgXworld digital platform is a classic win-win situation: it offers you access to services that were previously not available in this form. And we can make processes even more efficient in contact with you. It is an extraordinary offer that we will successively expand. Joining our arburgXworld is free of charge. Central apps such as our Shop and our ServiceCenter provide a better overview right from the start, make communication easier, increase flexibility and speed up responses. And they can save you substantial amounts of time and costs. Anyone looking for even more functionality can expand their digital possibilities at any time in a targeted manner.

**REGISTER**  
**NOW**



Companies wishing to use access to ARBURG's digital service world can register at [www.arburgXworld.com](http://www.arburgXworld.com)



# FACILITATORS: arburgGREENworld

// Our arburgGREENworld program is both a statement and a milestone. It contains solutions that customers can use directly at their own facilities. Innovations and internal processes that we implement on a daily basis at our sole production site in Lossburg (Germany) and then transfer to our subsidiaries all over the world. The aim is to continuously increase resource efficiency and to implement a circular economy in all areas of industrial production. //

**i** Further information:  
arburgGREENworld brochure



**GREENmachine**

Efficient and resource-friendly machine technology

**GREENproduction**

Innovative processes and networked production processes

**GREENservices**

Services covering all aspects of plastics processing

**GREENenvironment**

Manufacturing and business processes at ARBURG



Service Allround: Whenever and wherever you need us – we are there for you.



# ALL-ROUND SUPPORT: ARBURG SERVICE

// For us at ARBURG, service is not just something we do, but rather an expression of an attitude: When you use our injection moulding or additive manufacturing technology, you can rest assured of comprehensive support over the entire system lifetime, in the knowledge that you can rely on our world-class, responsive service offerings. Be it the delivery of genuine parts, telephone hotline, immediate deployment of our service technicians or specialist training courses: We do our utmost to ensure that you can produce efficiently and successfully. //

Spare parts and direct support  
on the ground in around

**100**  
COUNTRIES



Further information:  
Service worldwide brochure





**ARBURG**

[www.arburg.com](http://www.arburg.com)

ARBURG  
Material: 3742  
Cable  
Length: 10m  
Weight: 0.5kg



Scan this code to visit our  
Media Centre: in-depth,  
captivating, entertaining.

**ARBURG GmbH + Co KG**  
Arthur-Hehl-Strasse  
72290 Lossburg  
Tel.: +49 7446 33-0  
[www.arburg.com](http://www.arburg.com)  
[contact@arburg.com](mailto:contact@arburg.com)

**WIR SIND DA.**

© 2024 ARBURG GmbH + Co KG | All data and technical information have been compiled with great care. However we accept no responsibility for correctness. Individual illustrations and information may deviate from the actual delivery condition of the machine. The relevant valid operating instructions are applicable for the installation and operation of the machine.